



REV.	ECN NO.	REVISED	DATE

## NOTE:

## 1.MATERIAL:

a.HOUSING:PA66

b.CONTACT:BRASS

(SURFACE PLATING: Ni 100u"~120u")

SEE ORDERING INFORMATION

## 2.ELECTRIC:

a.CONTACT RESISTANCE: 30 MILLIOHMS MAX

b.INSULATION RESISTANCE: 1000 MEGA OHMS MIN

c.DIELECTNIC VOLTAGE: 500V AC ONE SEC LEVEL

d.OPERATING TEMPERATURE: -25°C~ +85°C

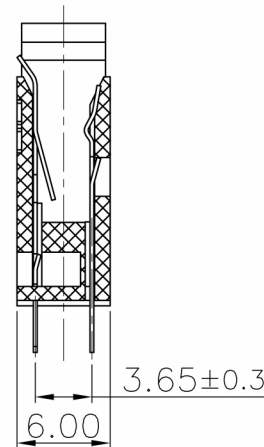
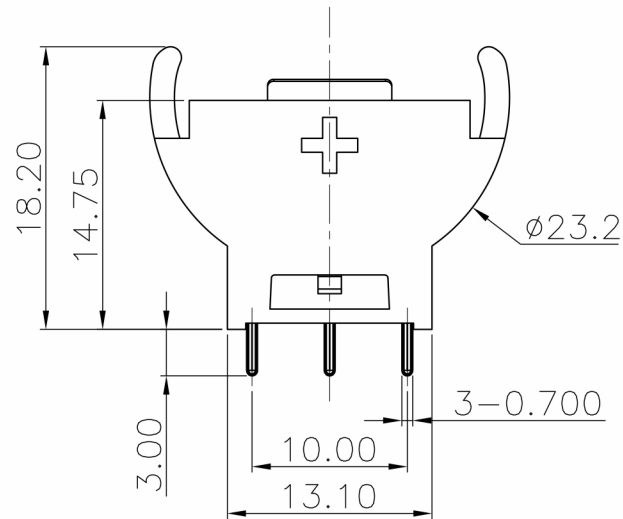

## ORDERING INFORMATION

BS-05-A\*\*\*001

电池座系列

BS-05系列

DIP 90° TYPE

PLATING:

A-Au1U"

J-Ni100U"~120U"

K-Sn100U"~120U"

MATERIAL:

1A-PBT BLACK

1B-PA66 BLACK

2A-PPA BROWN

2B-PPA BLACK

3A-PPS BROWN

3B-PPS BLACK

4A-LCP WHITE

4B-LCP BLACK

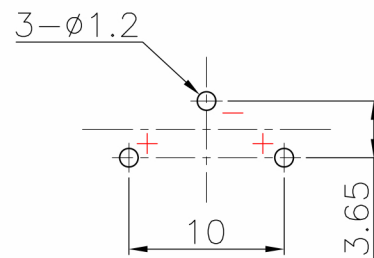
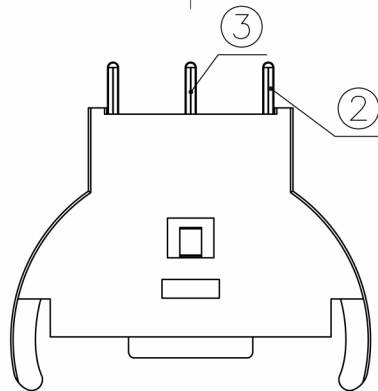
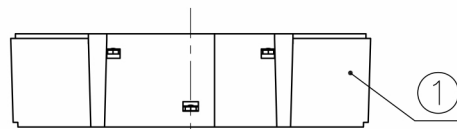
PCB Layout Diagram  
Top View

工程部

2017-07-12

ZW DANG

NO.	PART NAME	Q'TY	MATERIAL	PLATING & COLOR
3	TERMINAL(-)	1	BRASS, T=0.25mm	Ni Plating
2	TERMINAL(+)	1	BRASS, T=0.25mm	Ni Plating
1	HOUSING	1	PA66	BLACK

UNLESS OTHERWISE SPECIFIED TOLERANCES		深圳市芯魅能源科技有限公司 Shenzhen Makumi Energy Technology Co., Ltd			
DECIMALS: X :±0.30 X.X :±0.25 X.XX :±0.20 X.XXX :±0.10	ANGLES: X :±1° X.X :±0.5°	DSND	YangFeng	DATE	2017-07-12
		CHKD	ZhouRuicia	DATE	2017-07-12
		APVD	XueShun Yong	DATE	2017-07-12
WEIGHT: 1.64g		SCALE: 2:1	SIZE: A4	VIEW:	TITLE: BS-2032-5
SHEET 1 OF 1		UNIT: mm	REV.: A/0	OBJECT: MY	PART NO.: BS-05-A1BJ001
					DRAW NO.:MY-CP-0023